

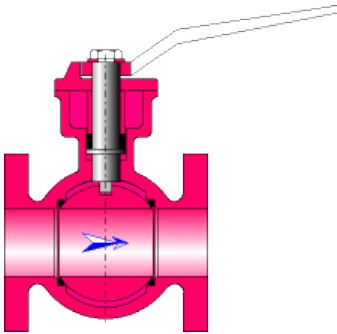

Ball valve (MILLER)



Model description:

This model of component calculates the minor head loss (pressure drop) generated by the flow in a ball valve installed in a straight pipe.

Model formulation:

Cross-sectional area (m²):

$$A = \pi \cdot \frac{D^2}{4}$$

Mean velocity (m/s):

$$U = \frac{Q}{A}$$

Mass flow rate (kg/s):

$$G = Q \cdot \rho$$

Reynolds number:

$$Re = \frac{U \cdot D}{\nu}$$

Local resistance coefficient:

- $Re \geq 10^4$ (turbulent flow)

$$K_{turb} = f(\alpha) \quad ([1] \text{ figure 14.17})$$

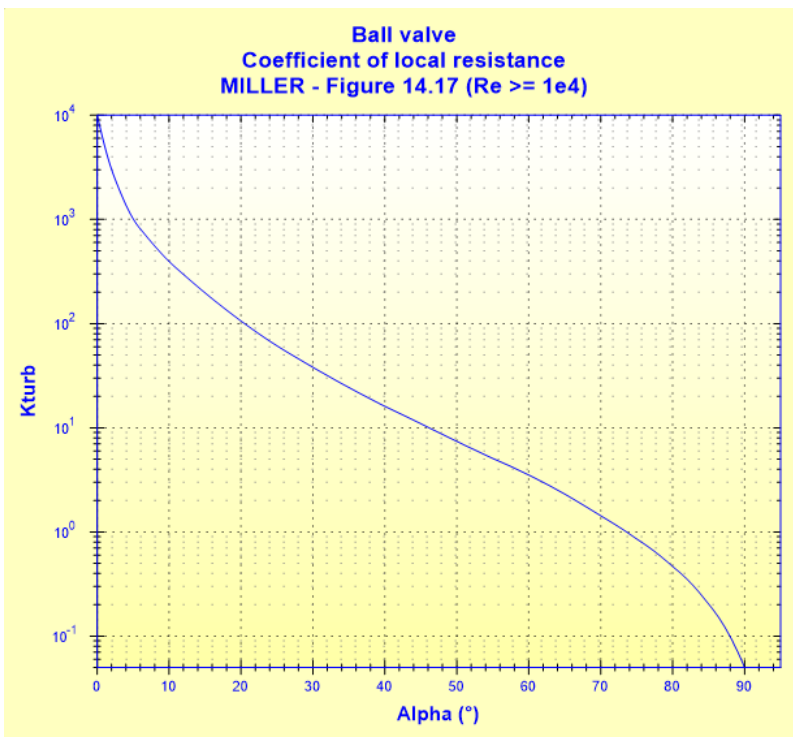

■ Re < 10⁴ (laminar flow)

$$K_{lam} = f(K_{turb}, Re) \quad ([1] \text{ figure 14.31})$$

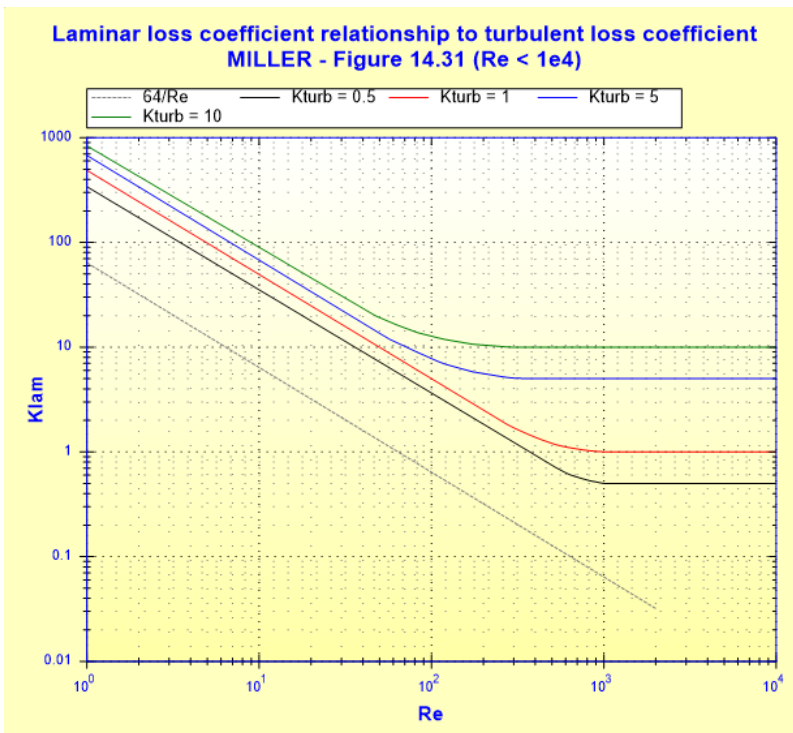

Reynolds Number Correction (Re < 10⁴):

$$C_{Re} = \frac{K_{lam}}{K_{turb}}$$

Total pressure loss coefficient (based on mean velocity):

■ turbulent flow (Re ≥ 10⁴):

$$K = K_{turb}$$

- laminar flow ($Re < 10^4$):

$$K = K_{lam}$$

Total pressure loss (Pa):

$$\Delta P = K \cdot \frac{\rho \cdot U^2}{2}$$

Total head loss of fluid (m):

$$\Delta H = K \cdot \frac{U^2}{2 \cdot g}$$

Hydraulic power loss (W):

$$Wh = \Delta P \cdot Q$$

Symbols, Definitions, SI Units:

D	Internal diameter (m)
A	Cross-sectional area (m^2)
Q	Volume flow rate (m^3/s)
G	Mass flow rate (kg/s)
U	Mean velocity (m/s)
Re	Reynolds number ()
α	Opening angle ($^\circ$)
K_{turb}	Local resistance coefficient for $Re \geq 10^4$ ()
K_{lam}	Local resistance coefficient for $Re < 10^4$ ()
C_{Re}	Reynolds number correction for $Re < 10^4$ ()
K	Total pressure loss coefficient (based on mean velocity) ()
ΔP	Total pressure loss (Pa)
ΔH	Total head loss of fluid (m)
Wh	Hydraulic power loss (W)
ρ	Fluid density (kg/m^3)
ν	Fluid kinematic viscosity (m^2/s)
g	Gravitational acceleration (m/s^2)

Validity range:

- any flow regime: laminar and turbulent

note: for laminar flow regime ($Re < 10^4$), the pressure loss coefficient " K_{lam} " is estimated

Example of application:

HydrauCalc 2020b - [Ball valve - MILLER (2nd Ed.)]

File Edit Preferences Calculation method Database Tools Help

Fluid characteristics

Fluid : Water @ 1 atm [HC]
Ref.: IAPWS IF97

Temperature : T 20 °C
Pressure : P 1.013 bar

Density : ρ 998.2061 kg/m³
Dynamic Viscosity : μ 0.00100159 N.s/m²
Kinematic Viscosity : ν 1.00340E-06 m²/s

Density Dyn. Visc. Kin. Visc.

Geometrical characteristics

Calculate
Help
Info

Pressure loss
 ΔP 8.2819E-05 bar
 ΔH 0.0008 m of fluid

Opening angle
90 °

G 4.9910 kg/s
Q 0.005 m³/s
U 1.288 m/s (Turbulent)

D 0.0703 m

Complementary results

Designation	Symbol	Value	Unit
Pipe cross-section area	A	0.003881508	m ²
Reynolds number	Re	90251	
<input checked="" type="checkbox"/> Coefficient of local resistance (Figure 14.17)	K _{turb}	0.01	
Pressure loss coefficient (based on the mean valve velocity)	K	0.01	
Hydraulic power loss	Wh	0.04140942	W

Divers HC

References:

[1] Internal Flow System, Second Edition, D.S. Miller